

### I.C.T Automatic Screwing Robot



#### Introduce:

This I.C.T machine include two parts: electric screwdriver and automatic screw feeder. It puts the automatic screw feeder together with the electric screwdriver in order to achieve the complement of screw transmission and fix, which can greatly improve the production efficiency and save manpower. Once the screwdriver is lifted after locking a screw, another screw will be sent continuously to continue the operation, which is particular suitable for the work piece of multi-station with the same specification.

#### Features:

1. Cost saving: High-efficiency operation is achieved by only one person, one person's efficiency amounts to 3-5 persons' efficiency;
2. High efficiency: The number of electric screwdriver of the Z axis is customizable according to customers' requirements. Several electric screwdrivers can work at the same time;
3. X,Y,Z axis adopt quality step motor with it's control system, make machine run smoothly and precisely;
4. Optional Windows 7 English operating system is very easy to work with, using the touch screen with the demonstrator for programming;
5. Self-developed advanced software, fool-style programming with wireless controller like play game, all parameters can be set in one program;
6. One worker can operate 2-3 robots, what this worker does is only pick and place fixture;
7. Robot is strictly customized based on requirements on products, in line with requirements of production line.

#### TOP Advantage:

1. More relax: Single equipment for single worker, Just finished loading, Reduce the labor intensity of workers;
2. Reliability: Automatic alarm system, working >20 hours;
3. Intelligent automatic equipment presents a new appearance of production line in factories;
4. Customization: Robot can be customized based on customers' requirements on products assembly.

#### Applications:

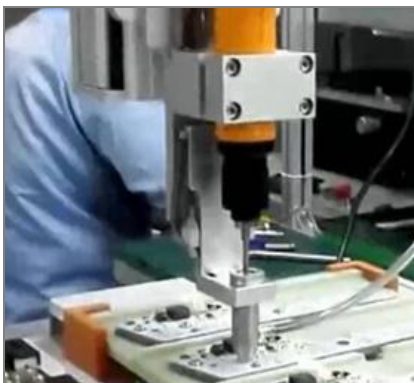



**Feeding System Option:**





Adsorption

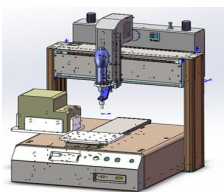

Air Blow

**Specification:**

Model	I.C.T-SCR300	I.C.T-SCR540	I.C.T-SCR640
Photo			
Max. Range Size	300*300mm, Z: 80mm	500*400mm, Z: 80mm	600*400mm, Z: 80mm
Head Number	1	1	2
Platform Number	1	2	2
Max Move Speed	X,Y axis: 600mm/s, Z axis: 400 mm/s		
Screwdriver	SD/KILEWS/HIOS		
Screw Feeding	Pick and Place, Magnetic		
Alarm System	Stripped Alarm		
Repeat Accuracy	±0.02mm		
Memory	999 Programs		
Programming	Traction Teaching Program		
Driving Mode	Closed-loop Motor		
Control Mode	Demonstrator+Touch Panel		
Air Pressure	4.5~6Kg/cm <sup>2</sup>		
Power Supply	AC:220±10%,50/60HZ(AC:110V)		

Dimension	670*540*690mm	670*590*690mm	1010*730*690mm
Weight	Approx 70kg	Approx 90kg	Approx 130kg

\* The data is obtained under ambient temperature of 25℃ and humidity of 60%.

**Materials List:**

No.	Item	Brand	Original
1	Rack	I.C.T	China
2	Screwdriver	KILEWS	China
3	Linear guide	HIWIN	Taiwan
4	Ball spline	TBI	Taiwan
5	Ball screw	PMI	Taiwan
6	Synchronous gear	MITSUBOSHI	Japan
7	Sensor	OMRON	Japan
8	Programming controller	HK/SY	China
9	Stepping motor	Shinon	Japan
10	Step driver	RCON	Japan

**Standard Accessories:**

No.	Item	Quantity
1	Handheld Programmer	2 pcs
2	Programmer Cable	2 pcs
3	Power Cable	1 pcs
4	Air Pressure Pipe	2 pcs
5	Allen screwdriver	1 pcs

\* Attachments may change with product upgrade. If different, please follow the new list.

**Dimension:**

I.C.T-SR300

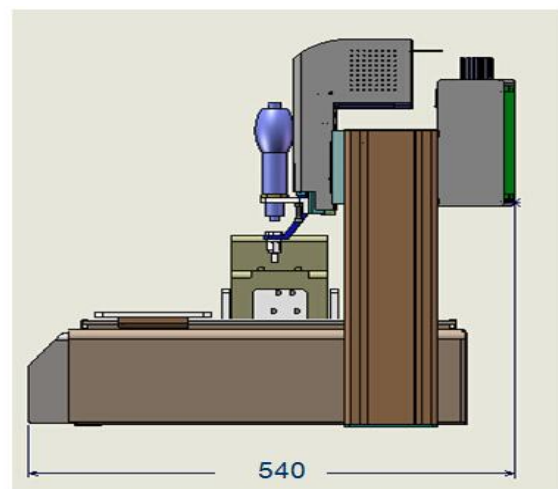
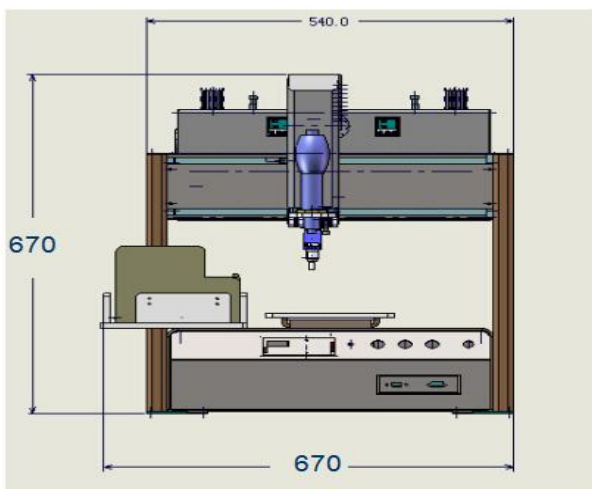

I.C.T-SR540

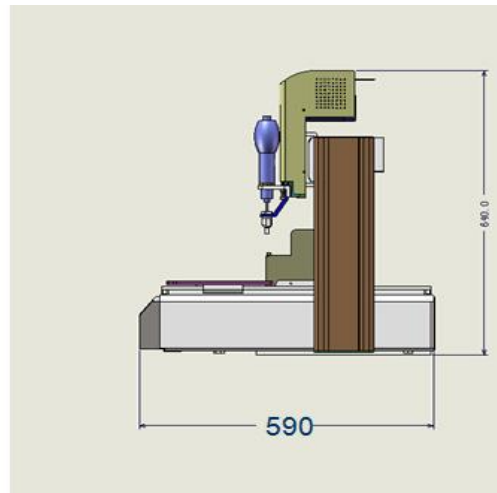
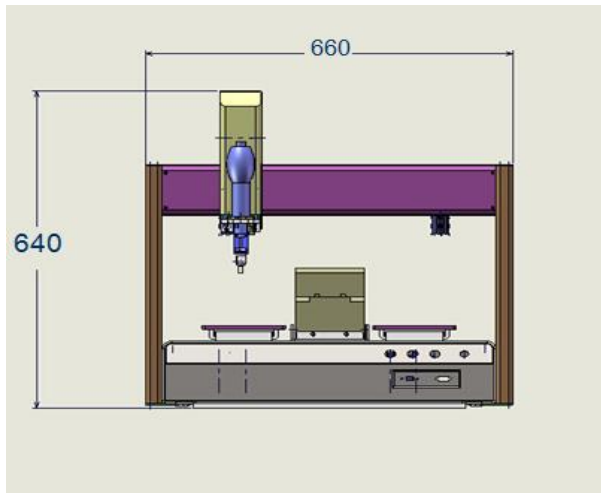

I.C.T-SR640

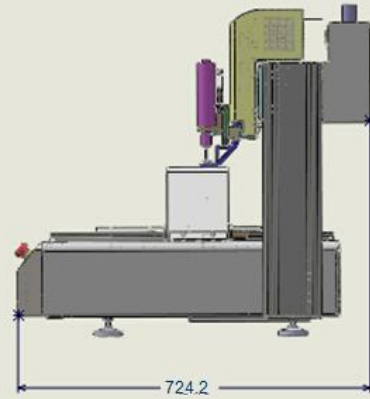
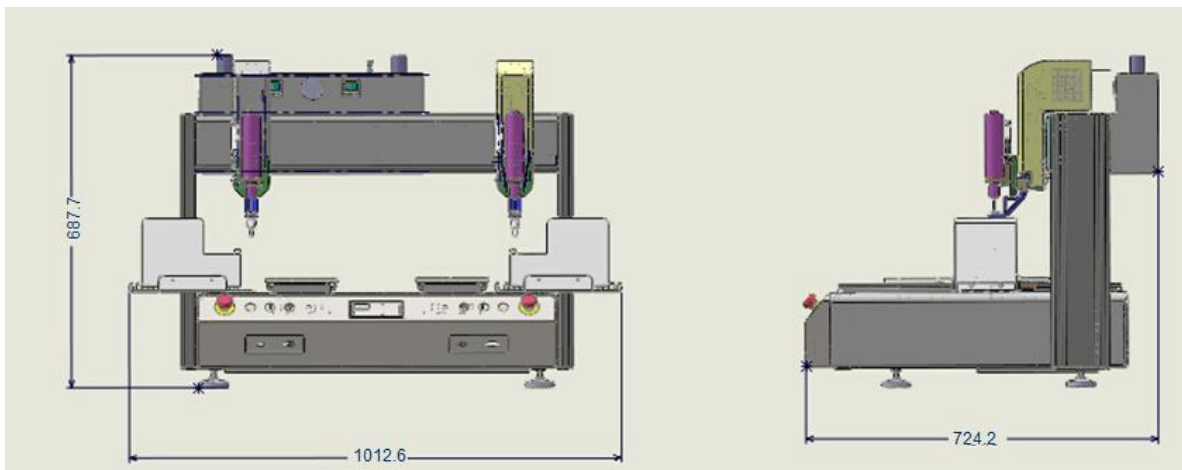

\* I.C.T keeps working on quality and performance, specifications and appearance may be updated without particular notice.

**Thanks for choosing I.C.T.**  
**I.C.T looks forward to win-win cooperation.**  
**Thank you.**