

Acrab-series Lead Free Wave Soldering Machine



Introduction:

I.C.T Acrab lead-free wave soldering machine has long-term positive feedback from customers. Its unparalleled heating performance and temperature control system meet the requirements of various welding processes, especially energy saving design has been a leading-edge product advantage, maximum reducing the using cost for customers.

Features:

1. Nozzle: Japan Kuroda Seiko nozzles, adjustable atomizing area, ensuring the long time spray uniformity and reliability.
2. Spray control: computer control or manually adjust switch, precise control the spray time, spray speed, economy and environmental protection, digital FLUX flow, spray flow, angle, density, width and other parameters can be recorded.
3. Cleaning device: automatic cleaning, modular design, easy maintenance.
4. Temperature Protection: third-party over-temperature protection, multiple protection layers to ensure safe operation.
5. Products comply with CE, CCC, UL and other standards and specifications.
6. User-friendly design: fault detection (such as heaters abnormal alarm, etc.), regular maintenance reminders, economy functions, emergency manual transmission function and tool-free maintenance, reduce equipment failure rates.
7. Heating module: horizontal reflow design makes each heating zones not influenced by adjacent zones to ensure accurate temperature curve, while ensuring high production capacity and heat exchange capacity, and achieve high adaptive capacity (to meet the soldering of automotive electronics, communications, electronics, computers and mobile phones, and other consumer electronics.).
8. Moving parts: computer adjustment, stepper motor control, accuracy and stability, to ensure accurate spray.
9. Temperature control: PLC + PID independent temperature control, real-time monitoring preheat temperature.
10. Core components: using imported components to ensure long-term stability of equipment operation, reduced maintenance costs.
11. Can choose different configurations of flux processing system, to ensure the furnace hall clean.
12. Closed-loop transmission speed control systems, transportation control accuracy $\pm 2\text{mm}/\text{min}$, ensuring speed more stable.
13. Dross Collection: Automatic dross return channel, the most energy-efficient channel design.

TOP Advantage:

Simple: Combined with advanced international concepts, based on the Oriental-designed operating system, easy to learn, easy to maintain.

Expertise: Learn imported reflow oven's advanced design concepts, and the components are using imported top brands.

Hedging: Import hardware configuration, low failure rate in production, more than a decade service life.

Safety: Based on the general rules of international design, close to imported reflow rating, the highest security level.

Stable: Mature software, hardware and top production processes ensures stability of each equipment.

Product:



Design Concept

Simplistic

Flexibility

Open Design

Modular Structure

Easy Maintenance

Tool-free Concept



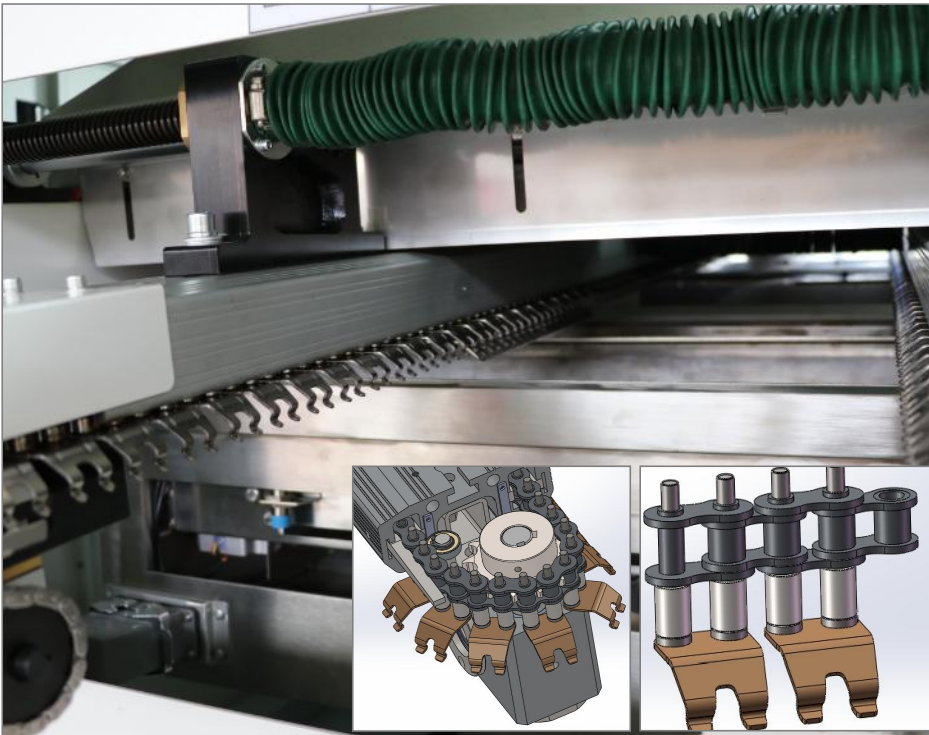

Conveyor System

Roller type double hook finger, force point increases roller sleeve, effectively reduce friction and wear.

Increase guide bracket and guide wheel, prevent chain knotting and clamping, and ensure transport stability.

Titanium finger no wetting and no deformation.

Full load > 60 kg.



Heat-resistant and high-density aluminium support, no deformation.

Transportation angle can be adjusted to ensure different welding processes.

Japanese transport motor, frequency conversion control, high accuracy of transport speed.

Central support is optional.

Titanium finger are standard, high temperature resistance, long life.



Spray System

316 stainless steel material, corrosion resistance.

Sealing structure design to prevent flux pollution.

Tool-free plug-in filter with self-contained air extraction system.

Cover is opened manually, conducive to maintenance.



Japanese high precision nozzle, uniform spraying volume.

Automatic cleaning function, prevent clogging.

The spraying range can be adjusted, suitable for different size PCB, saving flux.

Hose adopts anticorrosive material.

Barrier-type safety design, flux will not leak.



The whole drawer modular retractable structure.

TE brand plug-in link structure, tool-free maintenance mode, more maintenance space, reduce maintenance time.

Stepper motor drive mode, stability higher than cylinder.

All using anti-corrosion materials.

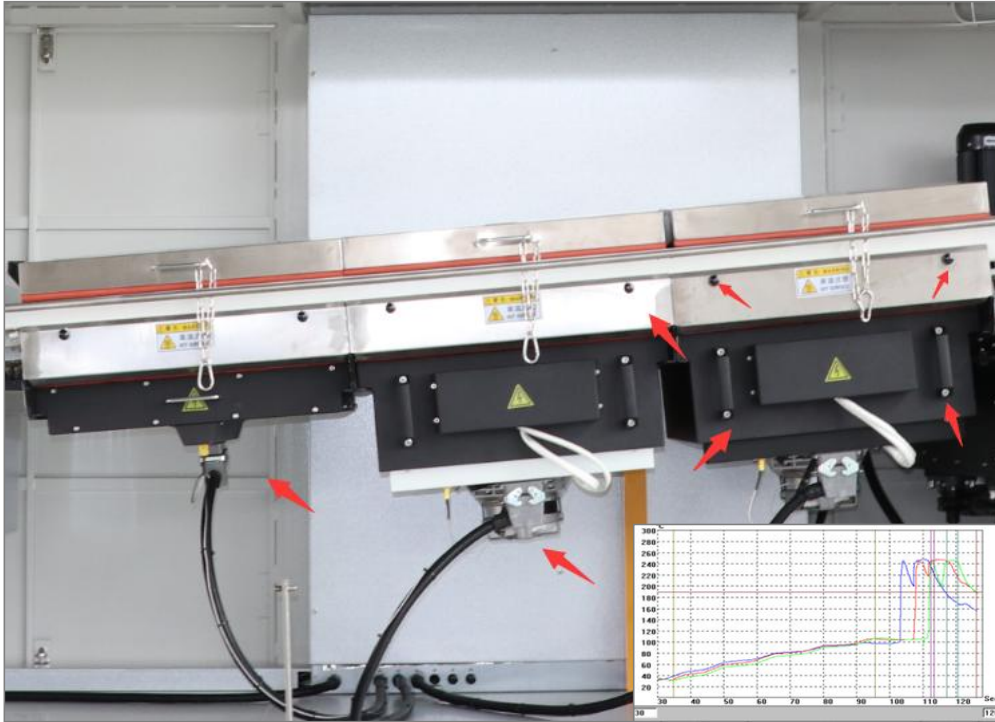

Preheating System

Efficient and stable heat conduction.
Design structure for maximizing preheating area.

All round high temperature cotton design to ensure temperature stability.

Heat-generating and heat-conducting parts and motors adopt top brands.

Addressing the technological challenges of different Products.



Modular design concept.

Drawer structure.

Maintenance plug-in design, tool-free maintenance mode.

IR and hot air preheating structure.

Flexible interchange of different preheating modules.

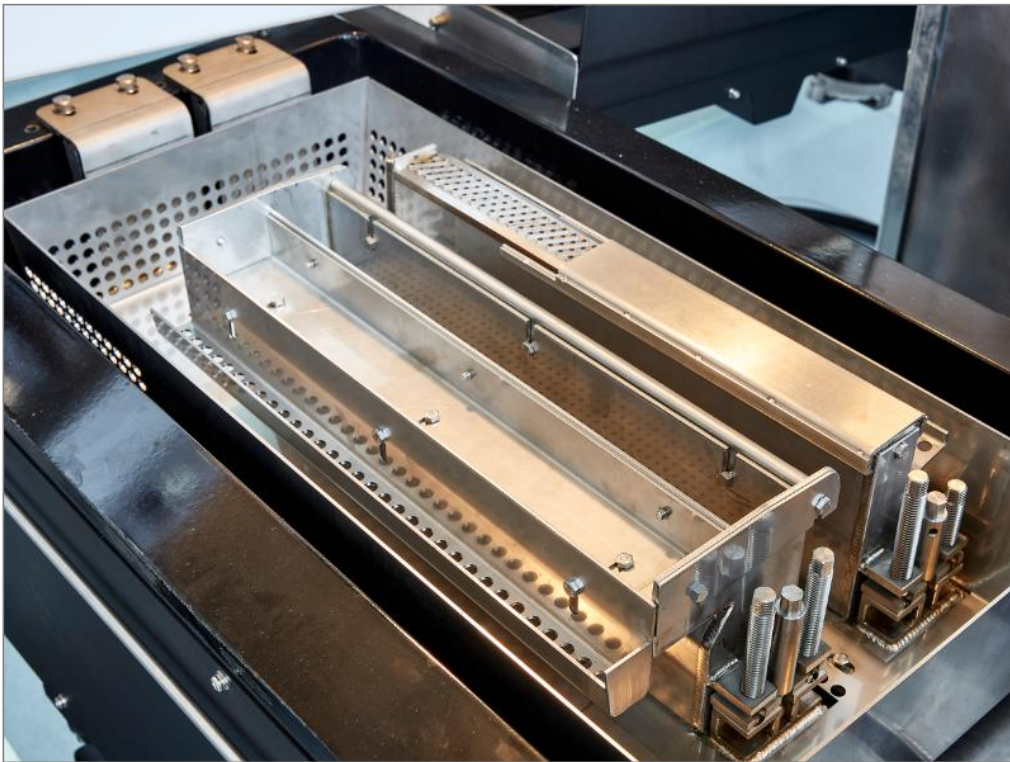

Soldering System

- Steady solder flow channel design.
- Wave peak stationarity less than 0.5mm.
- Easy maintenance design structure.
- Minimum oxidation of tin slag.
- Wave peak Inverter Control.



- Modular design concept.
- Maintenance plug-in design.
- Cast iron pot, prevent pot deformation.
- Heat-generating and heat-conducting parts and motors adopt top brands.
- Automatic tin feeding device is optional.

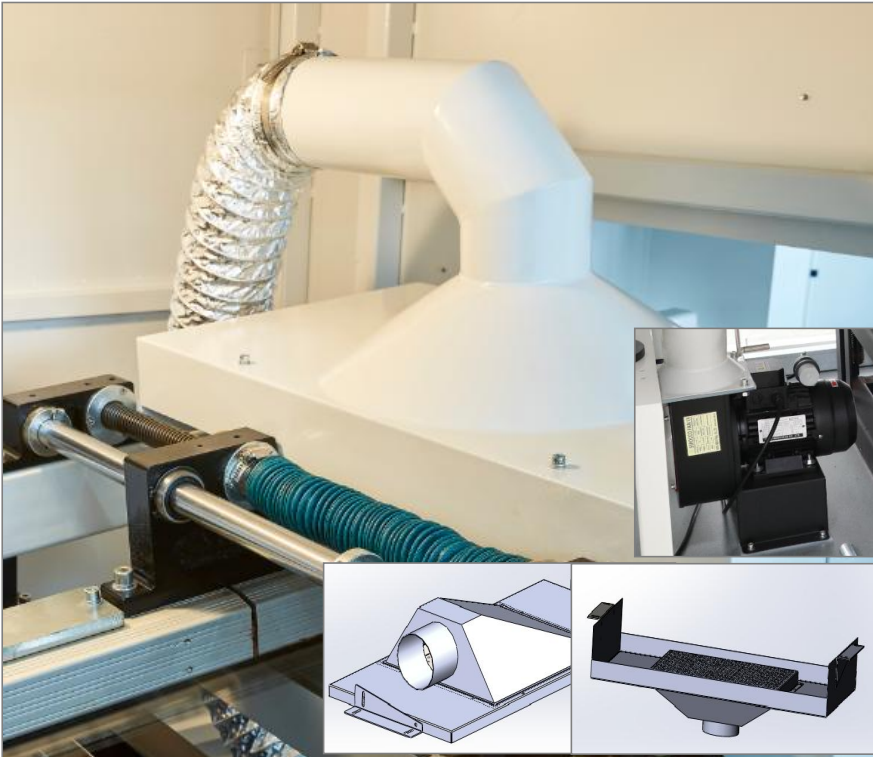

Cooling System

Top and bottom convection modes.

High Power Cooling Fan.



Control System

Humanized Operating Interface.

Standard circuit design, safe and reasonable.

Top brand for core parts.

Option:



External flux sprayer



Nitrogen protection

Materials List:

No.	Item	Brand	Original
1	Nozzle	Kuroda	Japan
2	High Temp. Motor	I.C.T	Taiwan
3	Heating Wire	OMEGA, Hotset	Japan, Germany
4	Guide rail	I.C.T	Taiwan materials
5	Sensor	OMRON, LEUCE, KEYENCE	Japan
6	Stepper motor	SANYO, Leadshine	Japan, China
7	Finger	I.C.T(titanium)	China
8	Solder pot	I.C.T(cast iron)	China
9	Software	I.C.T	China
10	Motor	BPMC, Oriental	Japan
11	Switch	SMC, Schneider	Japan, France
12	Bearing	NSK	Japan
13	Soft Cable	IGUS	Germany
14	Tanks chain	IGUS	Germany
15	PC	LENOVO, DELL	China, Germany
16	Solid relay	Carlogavazzi	Switzerland
17	Frequency converter	Delta	Taiwan
18	Button	Schneider	France

Specification:

Model	Acra350	Acra450
Dimension	4420*1420*1750mm	4420*1520*1750mm
Weight	Approx.1800kg	Approx.2100kg
Power Supply	3P5W, 380/220V 50Hz	3P5W, 380/220V 50Hz
Startup Power	33kw	33kw
Operation Power	8kw	8kw
Control System	PC+PLC	

Spray System		
Transmission Method	Step motor	
Spray Pressure	0.25Mpa--0.4Mpa	
Auto Flux Supply	Standard	
Flux Flow	10-100ml/min	
Exhaust	Top+Side exhaust	
Exhaust Diameter	Φ250mm	
Exhaust Capacity	25m ³ /min	
Preheating System		
Preheating Mode	Hot air/IR	
Control Mode	PID+SSR	
Preheating Zone	3	
Preheating Length	1800mm	
Preheating Temp.	(Room Temperature)-250℃	
Warm-up Time(min)	Approx.15min (Setting 150℃)	
Conveyor System		
PCB Width(mm)	50-350mm	50-450mm
Conveyor Direction	L~R (Option: R~L)	
Conveyor Speed	0-2000 (mm/min)	
Conveyor Height	750±20 (mm)	
Available PCB Height	Top 120mm (Option: 250mm), Bottom 15mm	
Finger	Spring Pressing Finger (Standard) Option: Spring Pressing Finger, Duck Mouth Finger	
Finger Cleaning	Brush	
Conveyor Width Control	Manually	
Conveyor Angle	4~7degree	
Soldering System		
Solder Pot Style	Mechanical Motor drive	
Solder Pot Material	Cast Iron	
Solder Pot Temperature	300℃	
Wave Adjustment	Inverter	
Solder Pot Capacity	Lead-free 500kg	
Solder Pot Warm-up Time	Approx.150min (Setting: 250℃)	
Cooling System		
Cooling Method	Cooling Fan	
Option: External flux sprayer, Nitrogen protection, MES system, Electric width adjustment		

Standard Accessories:

No.	Item	Quantity
1	Rail width adjustment handle	1 pcs
2	Manual transport handle	1 pcs
3	Tin pot in and out lifting handle	1 pcs

4	Force limiter wrench	1 pcs
5	8mm socket wrench	1 pcs
6	10mm socket wrench	1 pcs
7	Adjustable wrench	1 pcs
8	8mm open end wrench	1 pcs
9	High temperature gloves	1 pcs
10	Allen key	1 pcs
11	Phillips screwdriver	1 pcs
12	Flat-blade screwdriver	1 pcs
13	Through tin hole pin	1 pcs
14	Tin slag spoon	1 pcs
15	Tin slag colander	1 pcs
16	New double hook claw assembly	5 pcs
17	High temperature chain oil	1 pcs
18	Slag rake	1 pcs
19	Rosin barrel	1 pcs
20	Tool box	1 pcs

* I.C.T keeps working on quality and performance, specifications and appearance may be updated without particular notice.

Dimension:

Acrab350:

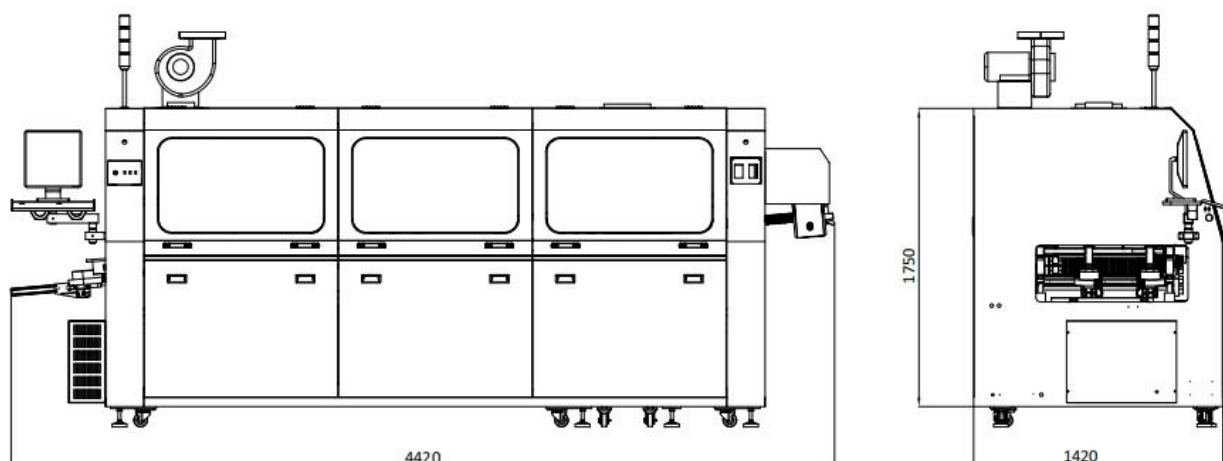

Acrab450:

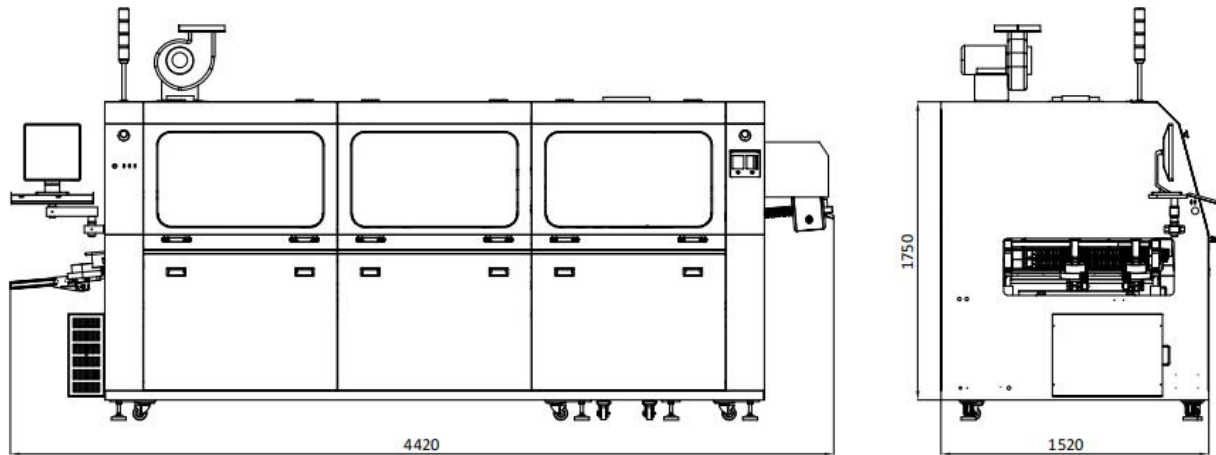

YouTube Video Link: https://youtu.be/_vqhU_PkZW0

Thanks for choosing I.C.T.
I.C.T looks forward to win-win cooperation.
Thank you.